

# 3" Pipe Threading Machine

MCC800

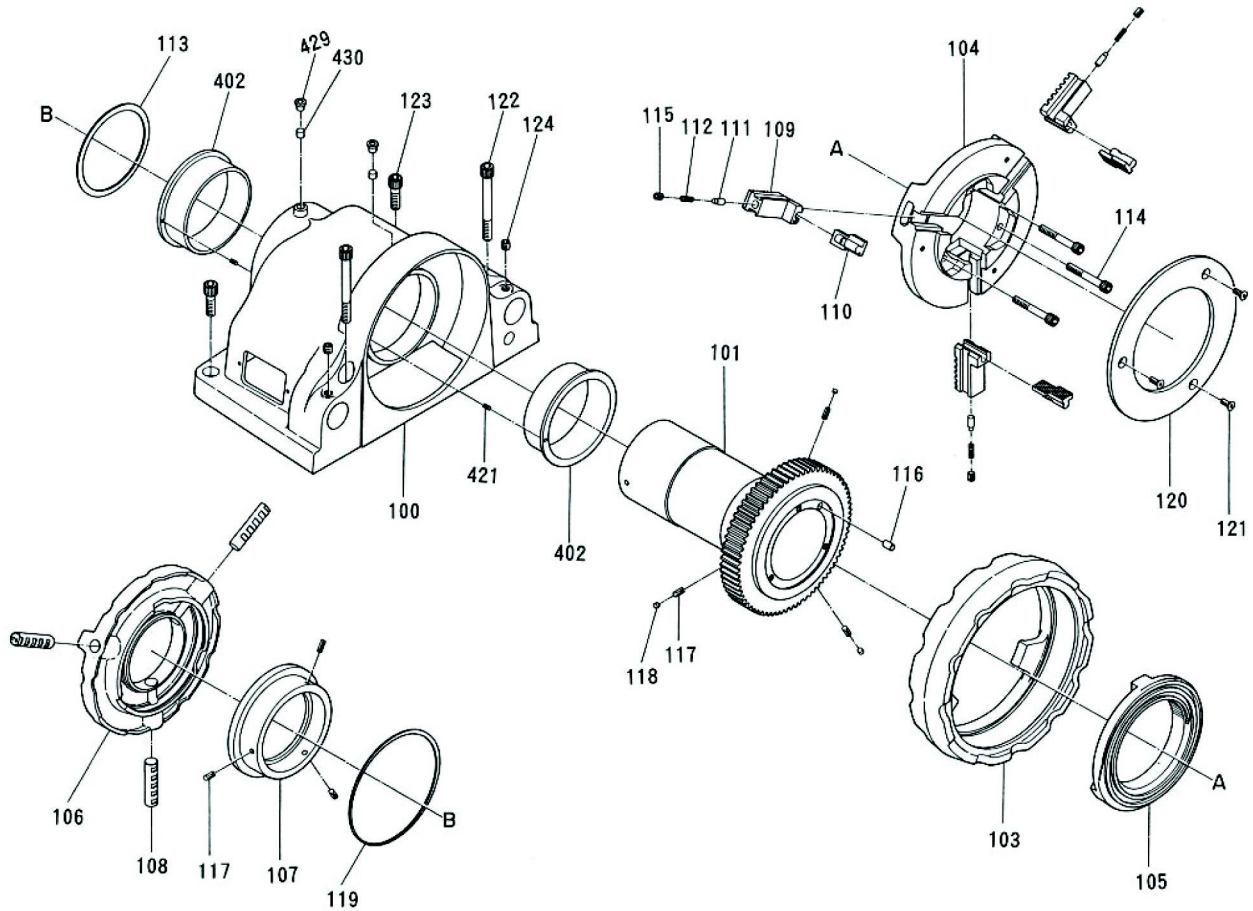

No.	Description	Qty
100	Head	1
101	Drive Shaft w Drive Shaft Gear	1
103	Hand Wheel	1
104	Chuck Body	1
105	Front Scroll	1
106	Rear Chuck Body	1
107	Rear Scroll	1
108	Holder Jaw (Round Type)	1 set
109	Chuck Jaw Body	1 set
110	Jaw	3
111	Pin	3
112	Spring	3
113	Fiber	1
114	Bolt (M8 x 60)	3
115	Screw (M8 x 10)	3
116	Pin (B8 x 22)	1
117	Spring Pin (6 x 14AW)	6
118	Vinyl Cap	3
119	Retaining Ring (AR-150)	1
120	Front Ring	1
121	Screw (M6 x 14)	3
122	Bolt (M10 x 100)	2
123	Bolt (M10 x 35)	2
124	Screw (M10 x 10, W point)	2
402	Oilless Bearing	2
421	Spring Pin (3 x 10AW)	2
429	Ball Oil Cup (3/8)	2
430	Felt (D9.5 x 8)	2

# 3" Pipe Threading Machine

MCC800

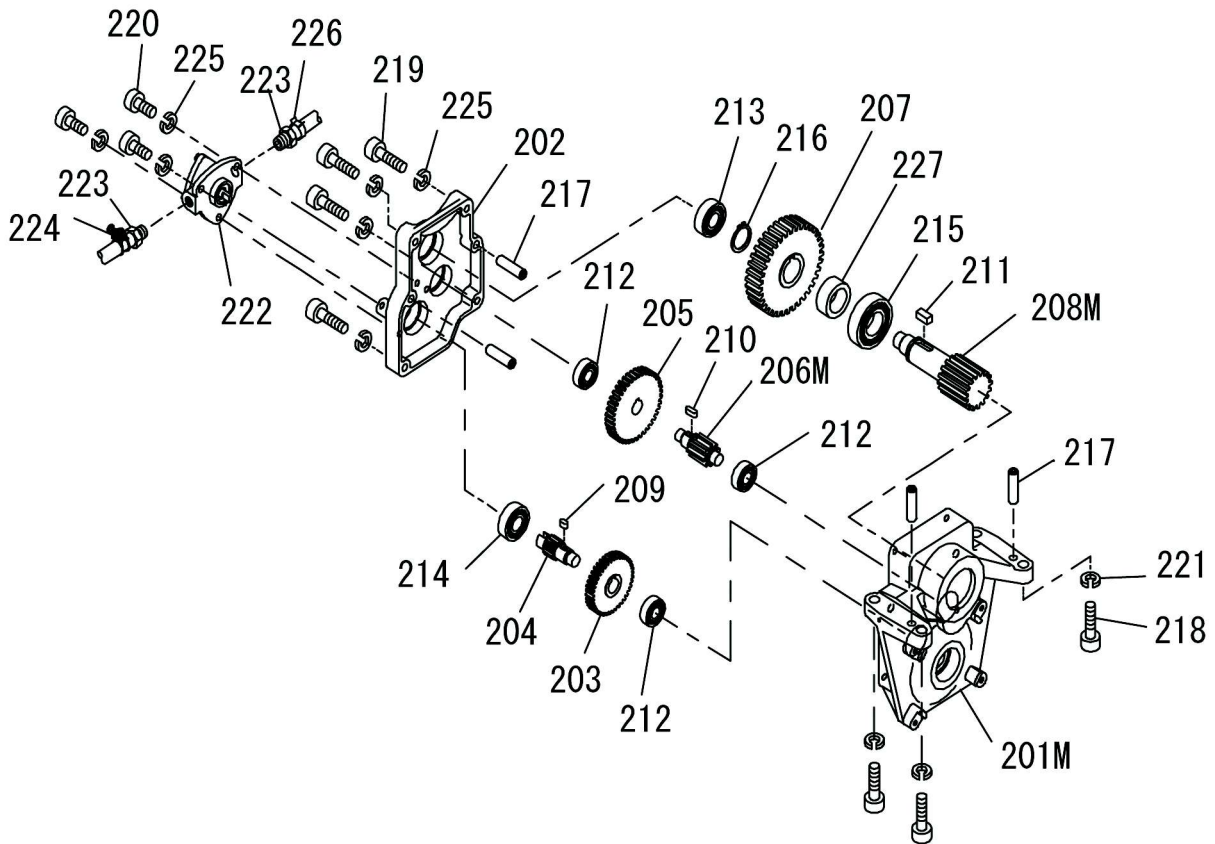

No.	Description	Qty
201M	Reduction Gear Main Body	1
202	Reduction Gear Cover	1
203	Gear (1)	1
204	Pinion (2)	1
205	Gear (2)	1
206M	Pinion (3)	1
207	Gear (3)	1
208M	Pinion (4)	1
209	Key (1) 5 x 5 x 9.5	1
210	Key (2) 5 x 5 x 14	1
211	Key (3) 7 x 7 x 16	1
212	Ball Bearing 6201	3
213	Ball Bearing 6202	1
214	Ball Bearing 6202LLU	1
215	Ball Bearing 6205ZZ	1
216	C-Shape Retaining Ring for 25	1
217	Pin B8 x 22	4
218	Bolt M10 x 30	4
219	Bolt M6 x 35	4
220	Bolt M6 x 16	3
221	Spring Wahser for M10	4
222	Trochoid Pump TOP-10AR	1
223	Hose Nipple PT1/8 x D7	2
224	Hose Clamp with Screw SM D10	1
225	Spring Washer for M6	7
226	Hose Clip KS-11 No.12	1
227	Collar	1

# 3" Pipe Threading Machine

MCC800

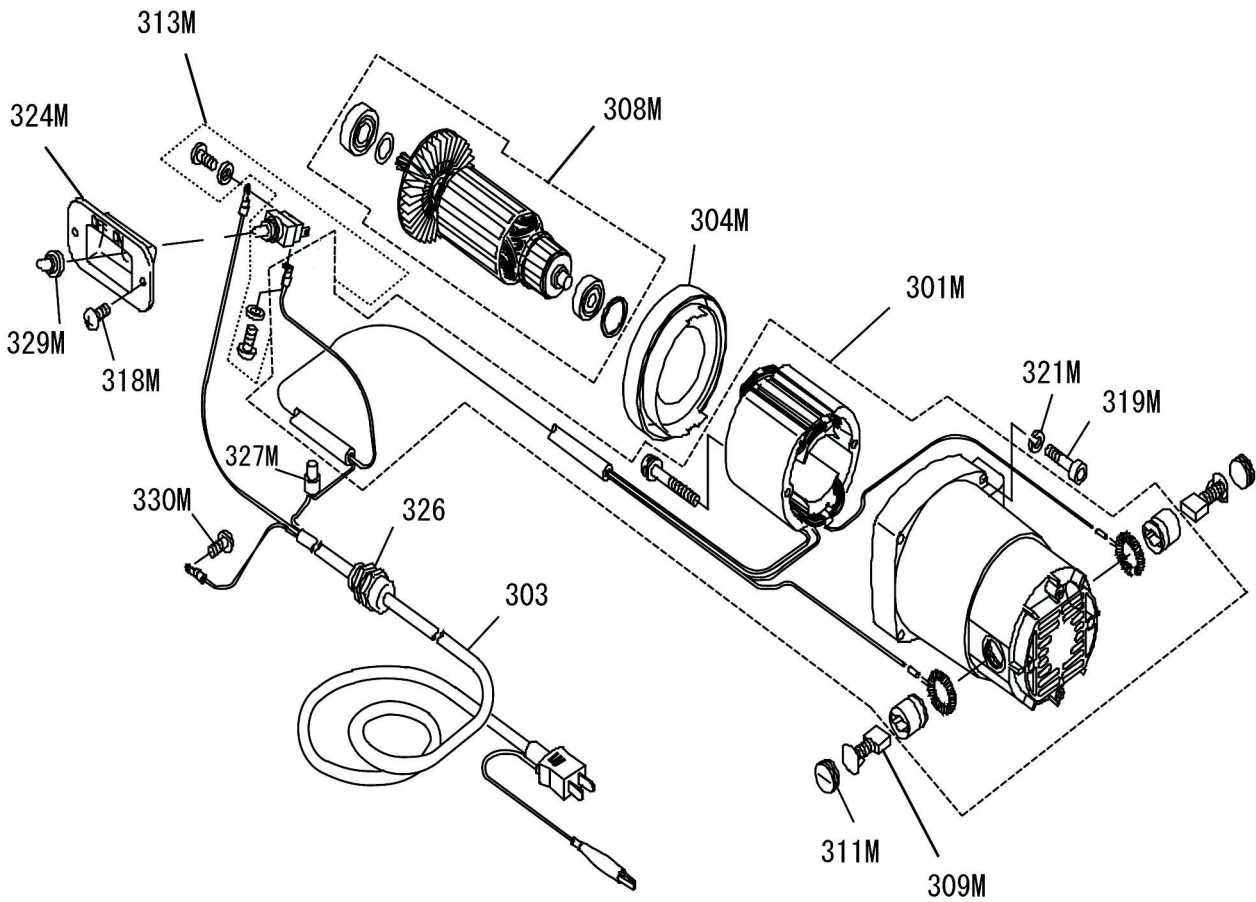

No.	Description	Qty
301M	Motor Housing Assy	1
303	Cable with Plug	1
304M	Baffle Plate	1
308M	Armature Assy	1
309M	Carbon Brush 204	2
311M	Brush Cap	2
313M	Switch SDT-125D-13U	1
318M	Screw M4 x12	2
319M	Bolt M5 x 40	4
321M	Spring Washer for M5	4
324M	Fitting Plate for Switch	1
326	Cable Gland ST-PF1/2	1
327M	Connection CE-5	1
329M	Waterproof Cap for Switch	1
330M	Screw M4 x 6	1

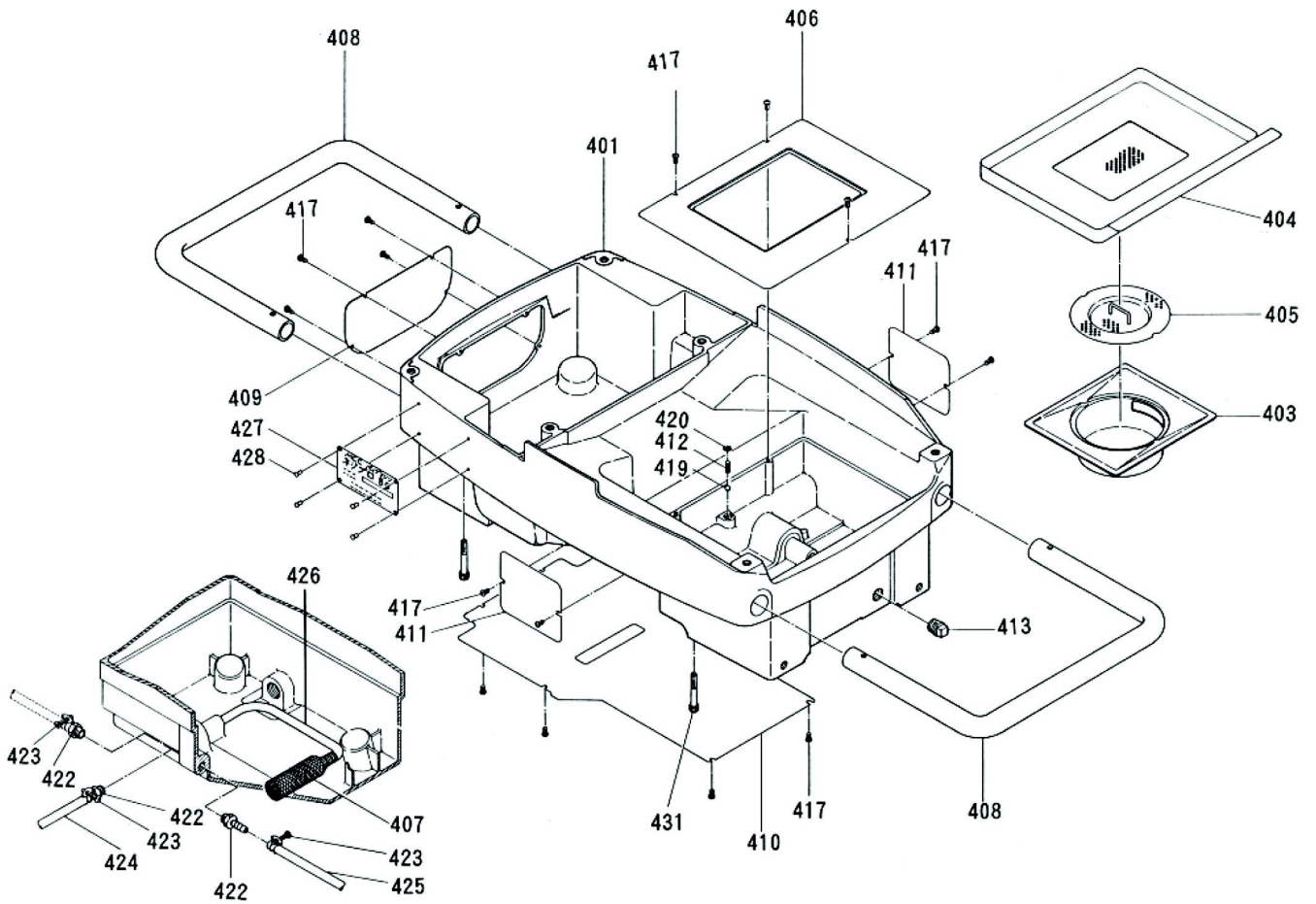

No.	Description	Qty
401	Main Body	1
403	Sink Filter	1
404	Chip Tray	1
405	Punching Plate	1
406	Cover for oil sink	1
407	Spring Filter	1
408	Handle	2
409	Cover for pump	1
410	Bottom Cover	1
411	Side Cover	2
412	Coil Spring	1
413	Plug (R3/4)	1
417	Screw (M4x6)	17
419	Steel Ball (6 ball)	1
420	Push Nut	1
422	Hose Nipple (PT1/8xD7)	3
423	Hose Clamp with Screw	3
424	Oil Feed Tube (1) (D10xD6.5x430)	1
425	Oil Feed Tube (2) (D10xD6.5x430)	1
426	Oil Feed Tube (D10x6.5x150)	1
427	Name Plate	1
428	Stud (No.6x6.4)	4
431	Bolt (M6x45)	4

3" Pipe Threading Machine  
MCC800

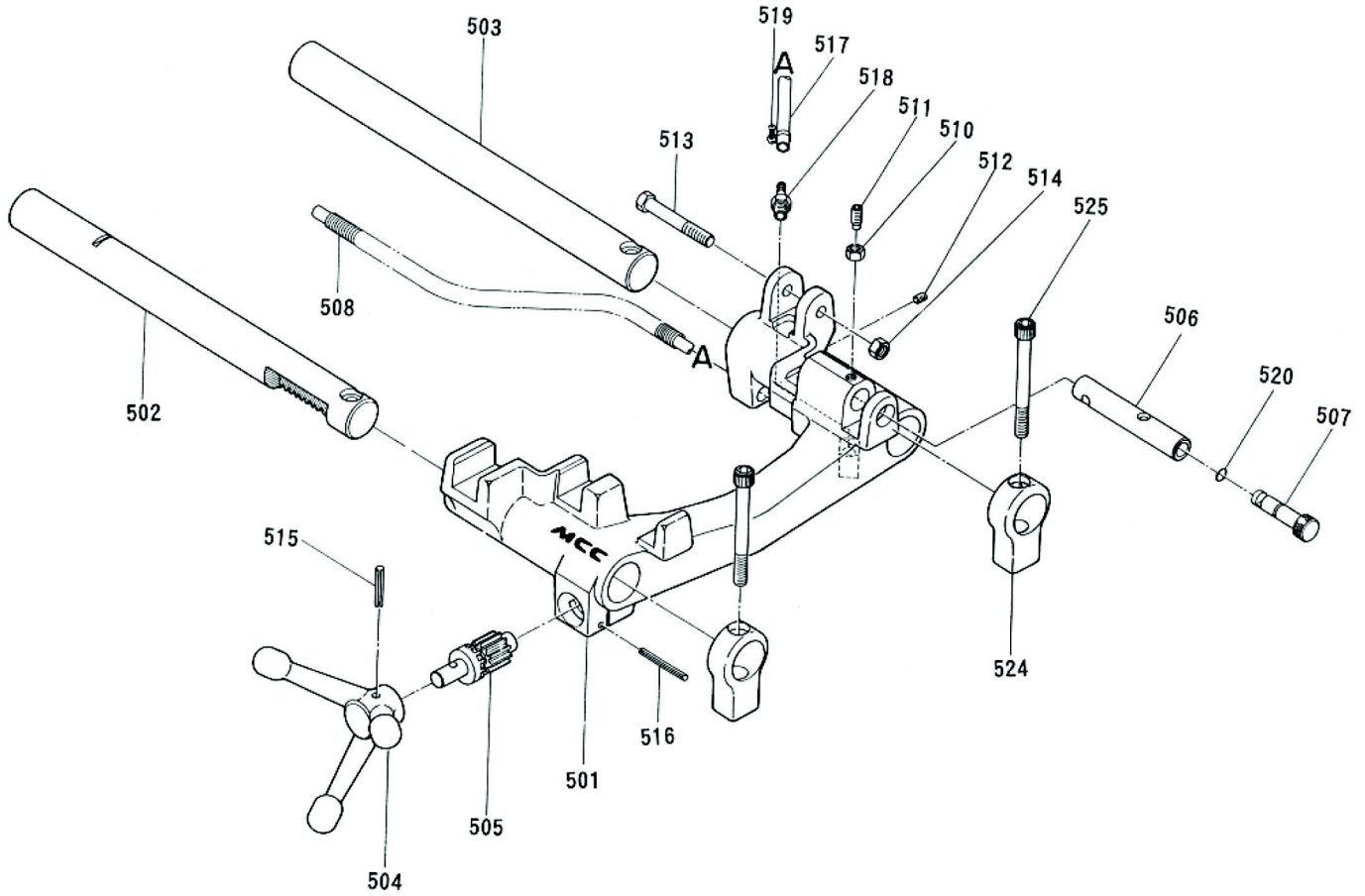

No.	Description	Qty
501	Carriage	1
502	Support Bar (Left)	1
503	Support Bar (Right)	1
504	Carriage Hand Wheel	1
505	Pinion for Rack	1
506	Die Head Pin	1
507	Oil Adjusting Pin	1
508	Coil Spring	1
510	Lock Nut	1
511	Screw (M8x20)	1
512	Screw (M6x8)	1
513	Bolt (M10x70)	1
514	Nut (M10)	1
515	Spring Pin (6x32AW)	1
516	Spring Pin (5x40AW)	1
517	Oil Feed Tube (3) (D10xD6.5x680)	1
518	Hose Nipple (PT1/8xD7)	1
519	Hose Clamp with Screw	1
520	O-Ring (P9)	1
524	Support Bar Stay	2
525	Bolt (M10x100)	2

3" Pipe Threading Machine  
MCC800

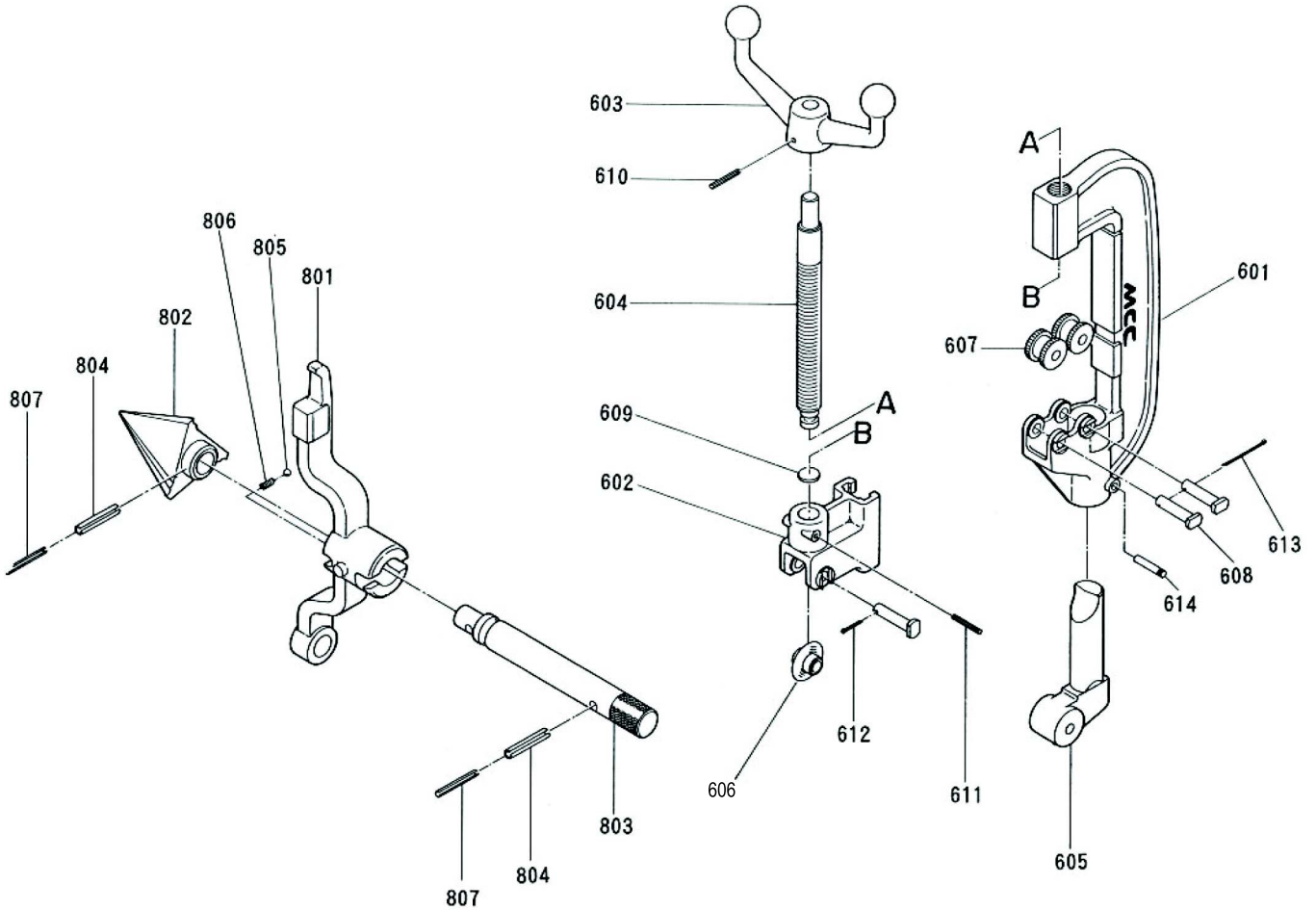

No.	Description	Qty
801	Reamer Arm	1
802	Reamer	1
803	Reamer Shaft	1
804	Spring Pin (8x45AW)	2
805	Steel Ball (6 Ball)	1
806	Spring	1
807	Spring Pin (5x45AW)	2

No.	Description	Qty
601	Cutter Frame	1
602	Cutter Housing	1
603	Handle	1
604	Feed Screw	1
605	Cutter Guide	1
606	Cutter Wheel (No. 3)	1
607	Cutter Roll	2
608	Pin	3
609	Washer (No.3)	1
610	Spring Pin (6x32 AW)	1
611	Spring Pin (4x22 AW)	1
612	Split Pin (2.5x15)	1
613	Split Pin (2.5x45)	1
614	Spring Pin (D6 x 32 AW)	1

Manual Die Head  
MD40, MD50, MD80

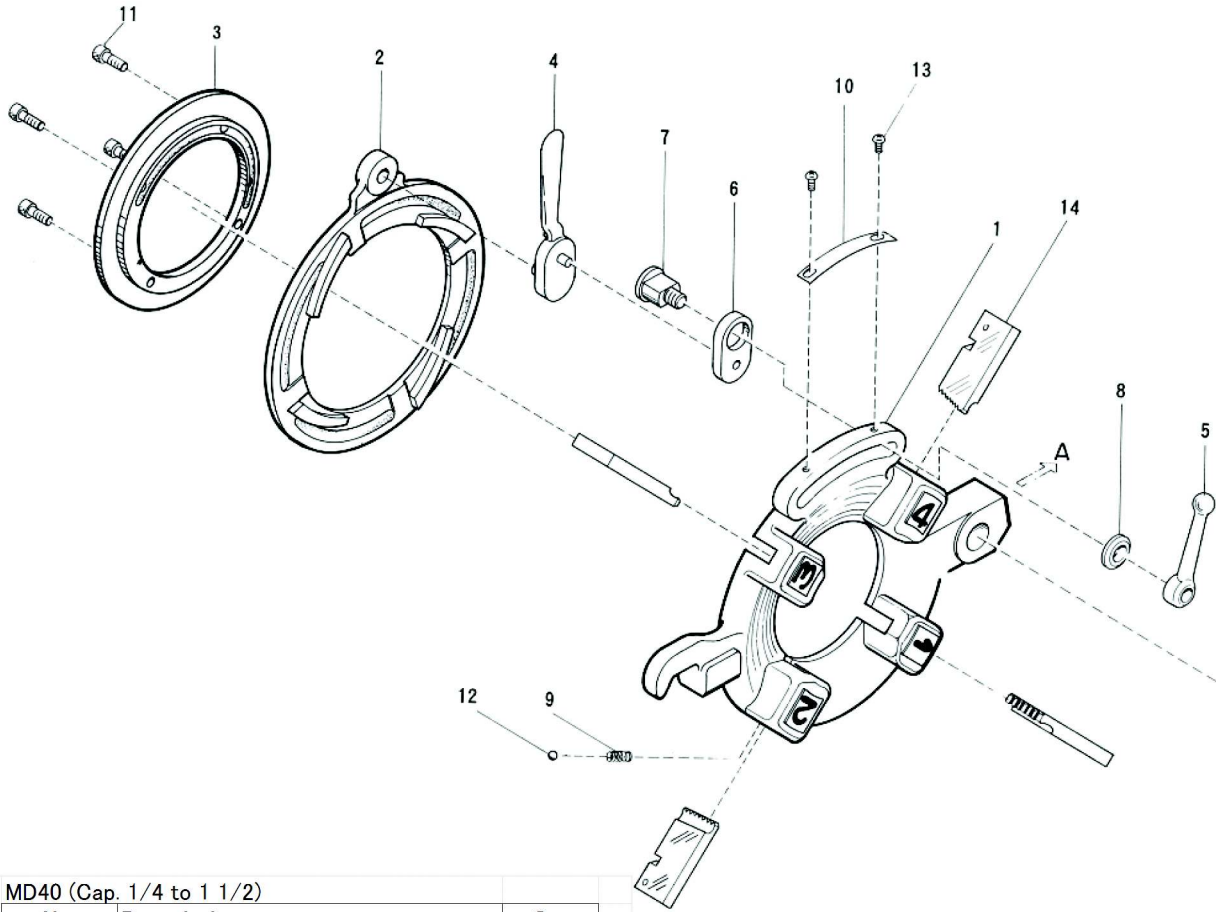

MD40 (Cap. 1/4 to 1 1/2)

No.	Description	Qty
1	Die Head (Body Only)	1
2	Cam Plate	1
3	Retaining Ring	1
4	Cam Lever	1
5	Clamping Lever	1
6	Link	1
7	Lock Screw	1
8	Washer	1
9	Spring	4
10	Size Gauge	1
11	Bolt (M6x18)	4
12	Steel Ball (5 ball)	4
13	Screw (M4 x 6)	2
14	Dies	1 set

MD50 (Cap. 1 to 2)

No.	Description	Qty
1	Die Head (Body Only)	1
2	Cam Plate	1
3	Retaining Ring	1
4	Cam Lever	1
5	Clamping Lever	1
6	Link	1
7	Lock Screw	1
8	Washer	1
9	Spring	4
10	Size Gauge	1
11	Bolt (M6x18)	4
12	Steel Ball (5 ball)	4
13	Screw (M4 x 6)	2
14	Dies	1 set

MD80 (Cap. 2 1/2 to 3)

No.	Part Name	Qty
1	Die Head (Body Only)	1
2	Cam Plate	1
3	Retaining Ring	1
4	Cam Lever	1
5	Clamping Lever	1
6	Link	1
7	Lock Screw	1
8	Washer	1
9	Spring	4
10	Size Gauge	1
11	Bolt (M6x18)	4
12	Steel Ball (5 ball)	4
13	Screw (M4 x 6)	2
14	Dies	1 set